

PARABODY

Serious Steel

822104 ADJUSTABLE SIT-UP BENCH

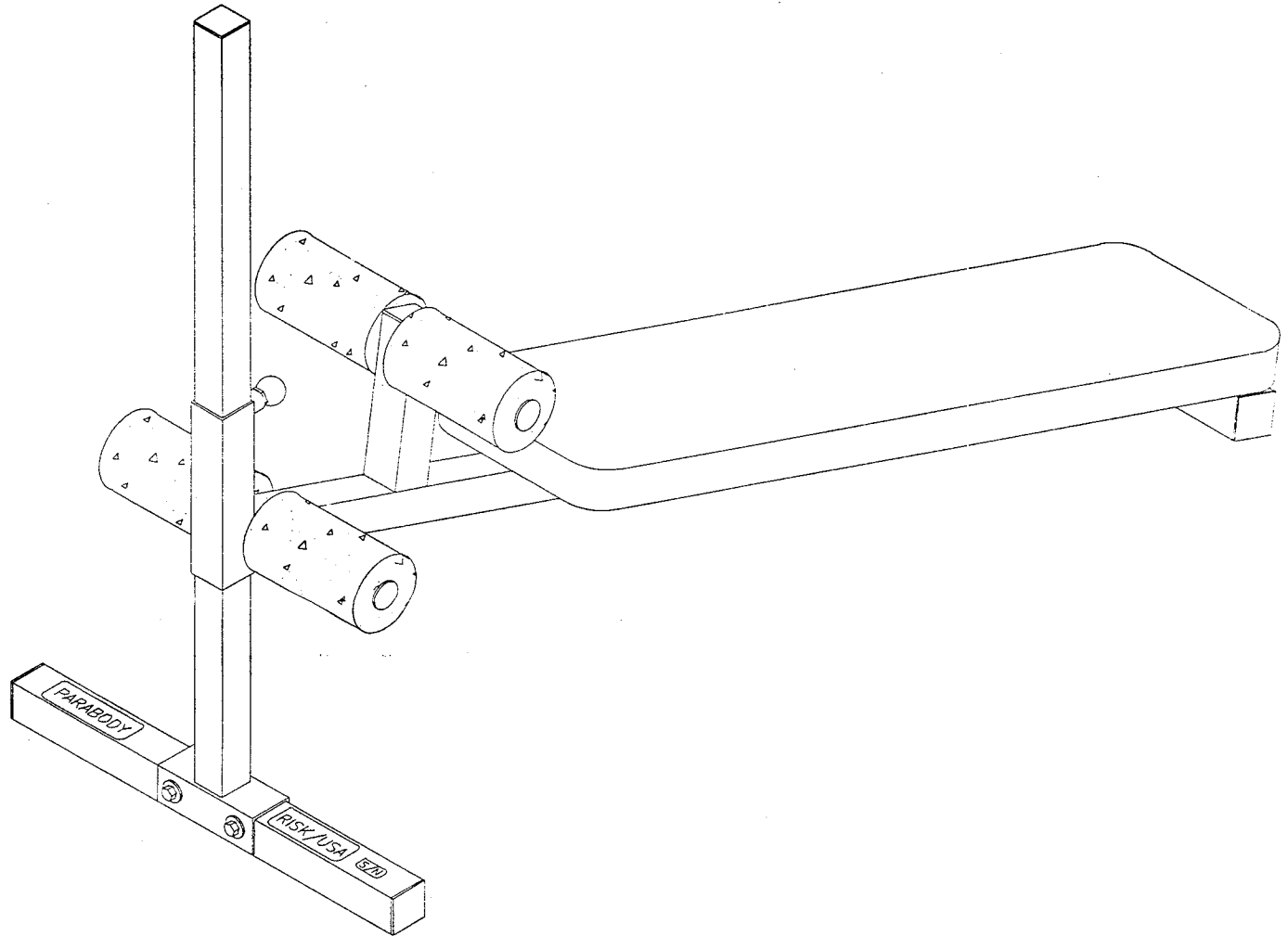

ASSEMBLY INSTRUCTIONS

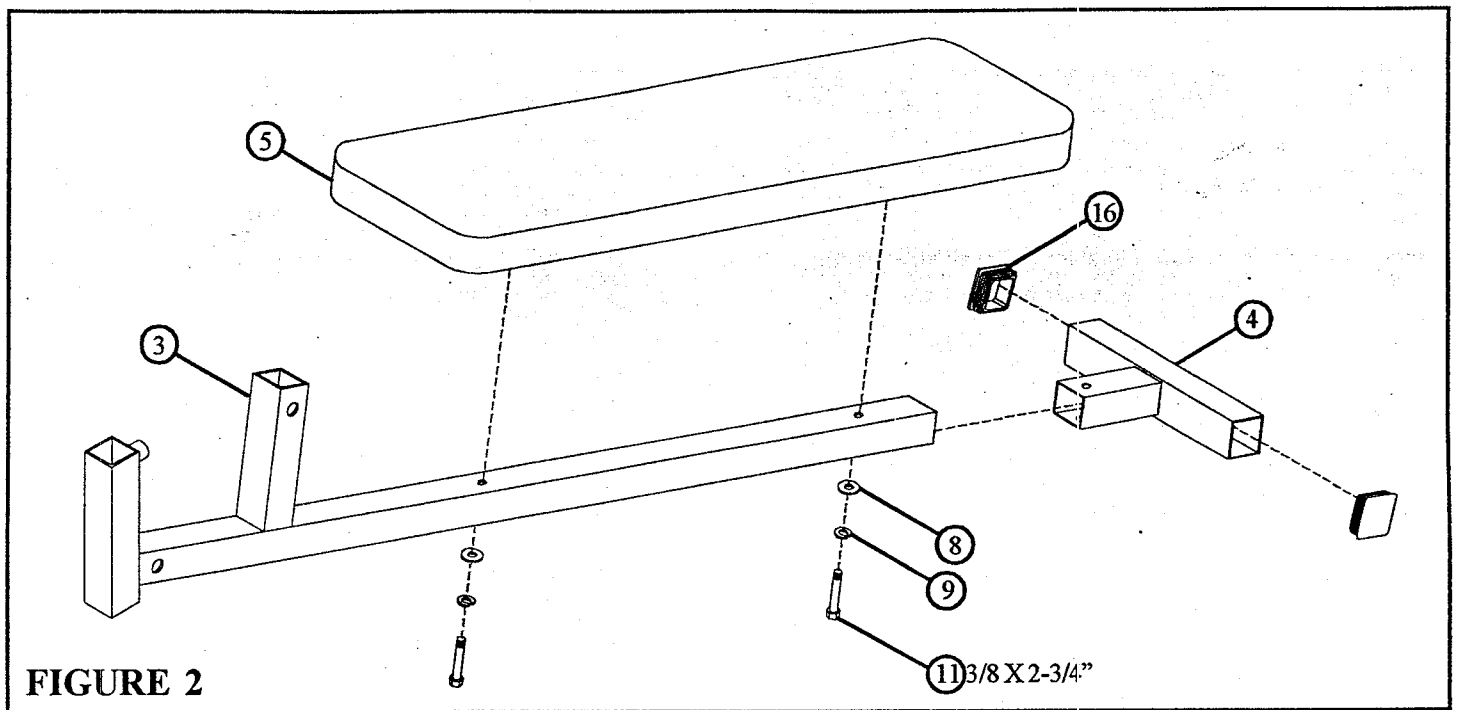

FIGURE 2

STEP 2:

- Insert two 2" SQ. END CAPS (16) into the ends of the BASE (4) as shown in FIGURE 2.
- **SECURELY** assemble the PAD (5) to the MAIN PAD SUPPORT (3) and BASE (4) using two 3/8" X 2-3/4" BOLTS (11), two 3/8" LOCK WASHERS (9), two 3/8" WASHERS (8), and two 3/8" LOCK NUTS (10). See FIGURE 2.

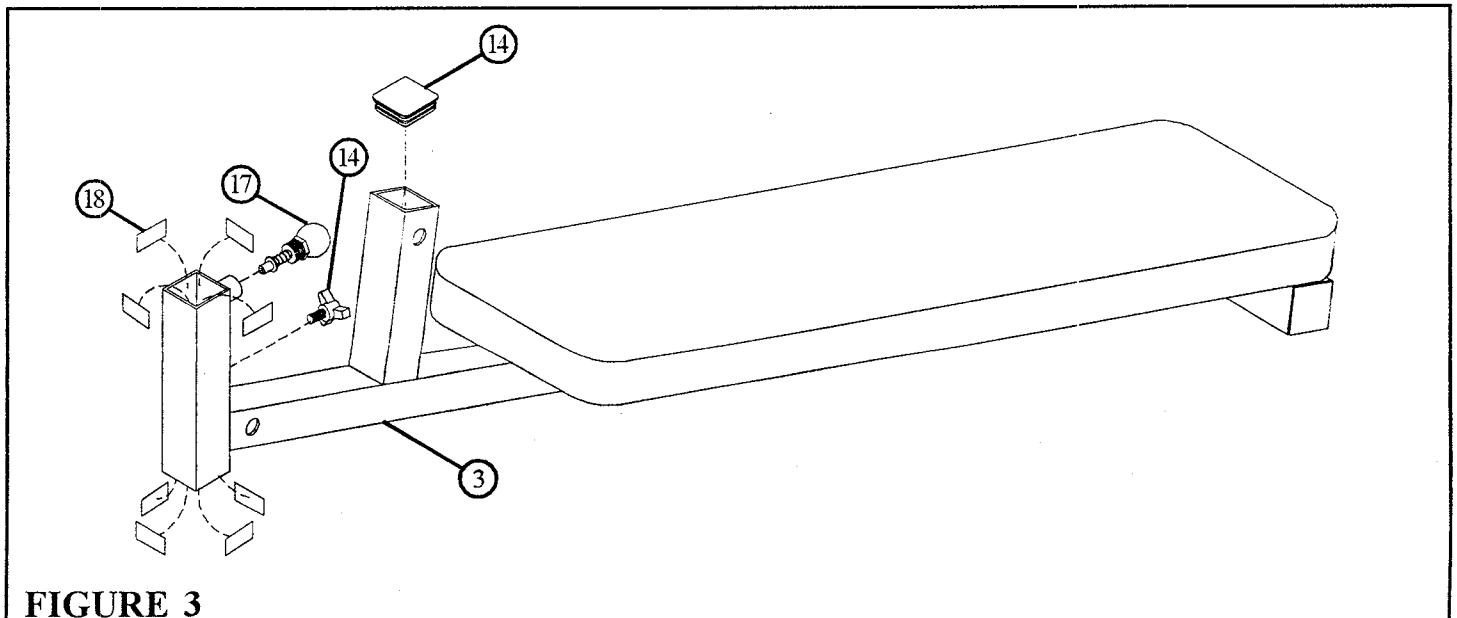
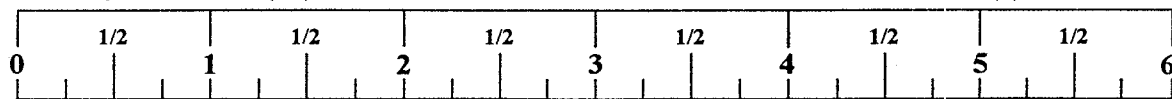

FIGURE 3

STEP 3:

- Apply eight 1-3/4 X 3/4" PARAGLIDES (18) to the INSIDE of the MAIN PAD SUPPORT (3) as shown in FIGURE 3. (NOTE: Thoroughly clean the inside surface before attaching PARAGLIDES.)
- Securely assemble one SPRING PIN ASSEMBLY (17) and one THUMBSCREW (14) to the MAIN PAD SUPPORT (3). See FIGURE 3.
- Insert one 2" SQ. END CAP (16) into the end of the tube on the MAIN PAD SUPPORT (3) as shown in FIGURE 3.



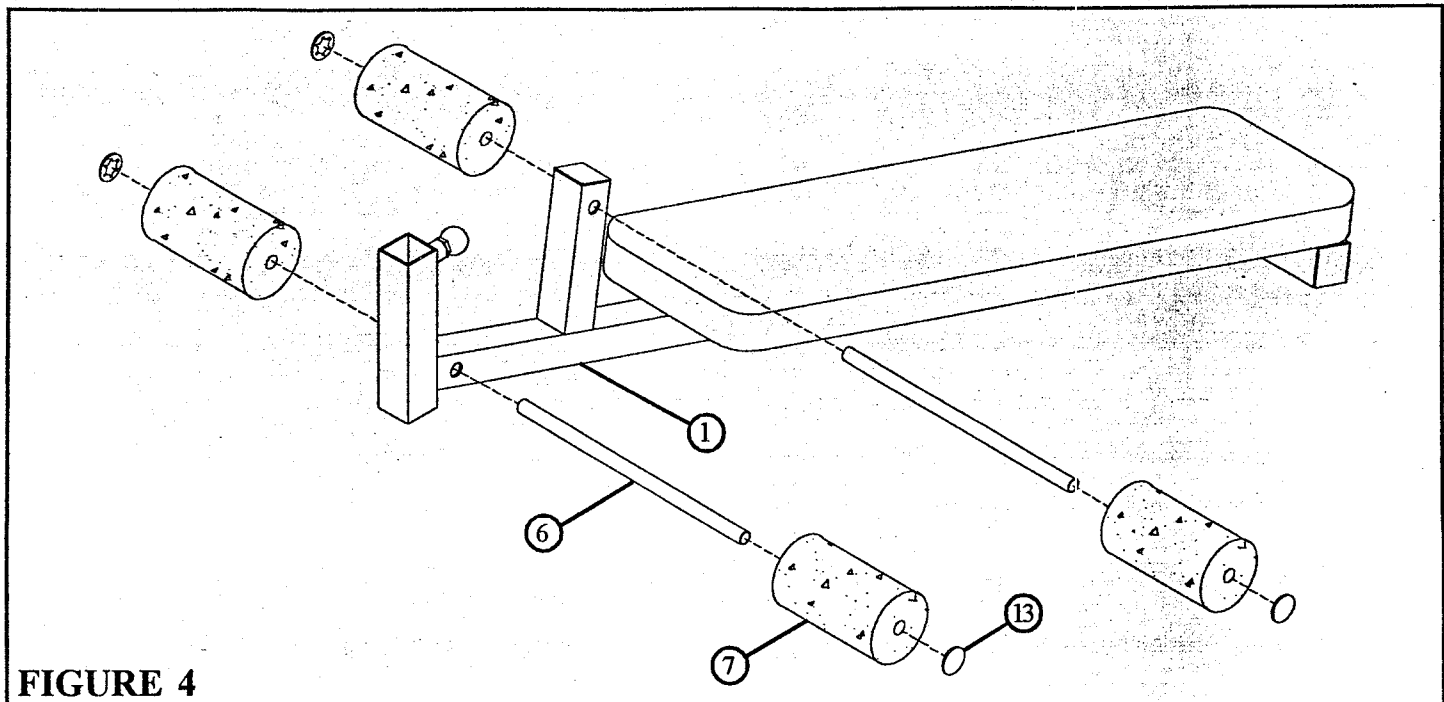

FIGURE 4

STEP 4:

- Slide the four ROLLER PADS (7) onto the MAIN PAD SUPPORT (3) using two 3/4 X 16" TUBES (6), and four STARLOCK COLLARS (13) as shown in FIGURE 4.

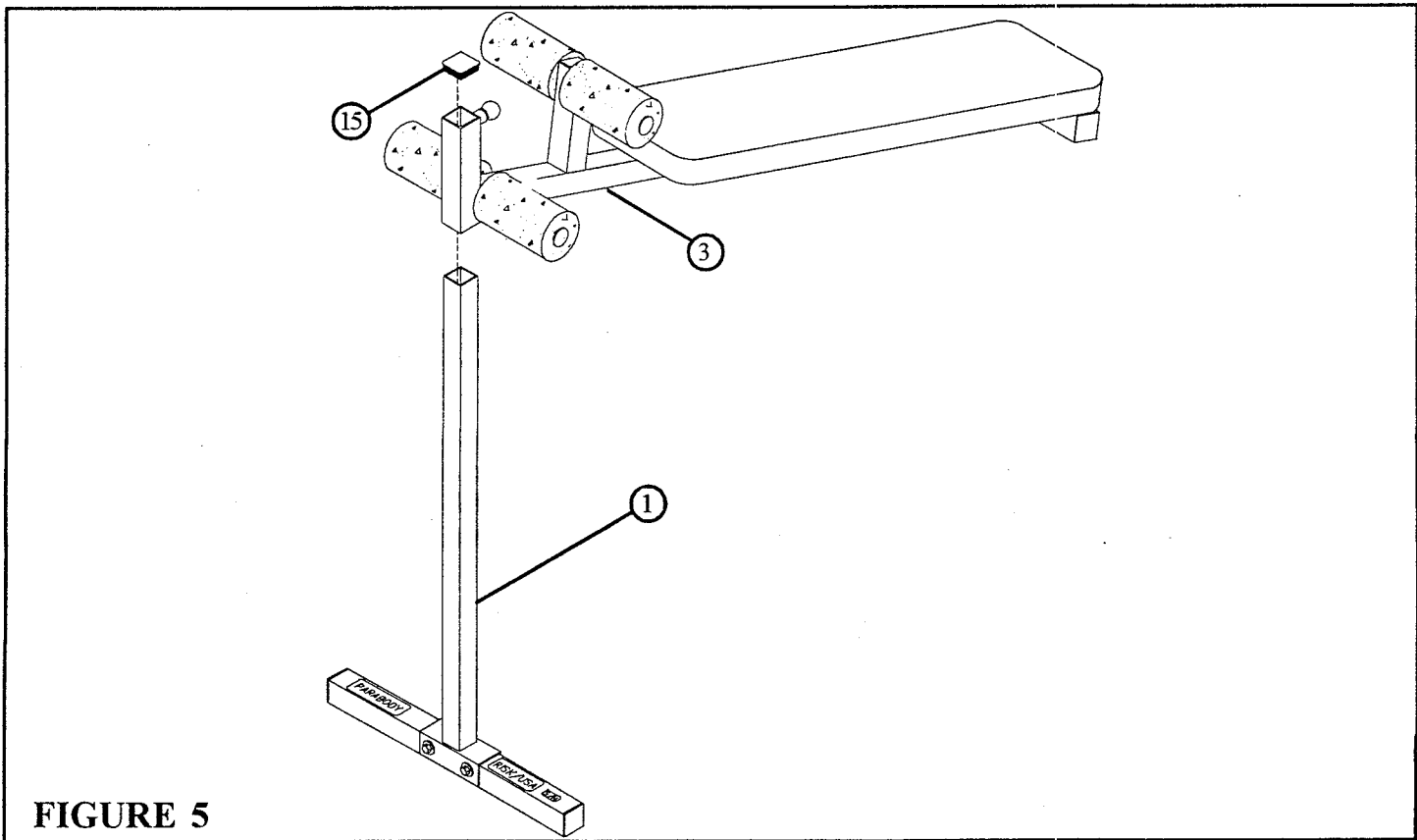

FIGURE 5

STEP 5:

- Pull back the SPRING PIN and **CAREFULLY** slide the MAIN PAD SUPPORT (3) over the FRONT BASE SUPPORT (1) as shown in FIGURE 5.
- Insert one 1-3/4" SQ. END CAP (15) into the ends of the FRONT BASE SUPPORT (1) as shown in FIGURE 5.

THIS CONCLUDES THE ASSEMBLY OF THE 822104 ADJUSTABLE SIT-UP BENCH

PARTS LIST

KEY	PART#	DESCRIPTION	QTY	KEY	PART#	DESCRIPTION	QTY
1	6522102	FRONT BASE SUPPORT	1	10	3102802	3/8" LOCK NUT	2
2	6483302	TUBE	1	11	3102922	3/8 X 2-3/4" BOLT	2
3	6522403	MAIN PAD SUPPORT	1	12	3102904	3/8 X 3" BOLT	2
4	6522603	BASE	1	13	3105401	STARLOCK COLLAR	4
5	6666502	PAD ASSEMBLY	1	14	6145801	THUMBSCREW	1
6	6125101	3/4 X 16" TUBE	2	15	6236701	1-3/4" SQ. END CAP	1
7	6194601	ROLLER PAD	2	16	6405201	2" SQ. END CAP	5
8	3102501	3/8" WASHER	6	17	6412001	SPRING PIN ASSEMBLY	1
9	3102601	3/8" LOCK WASHER	2		6416601	1-1/2 X 3/4" PARAGLIDE (QTY 8)	1

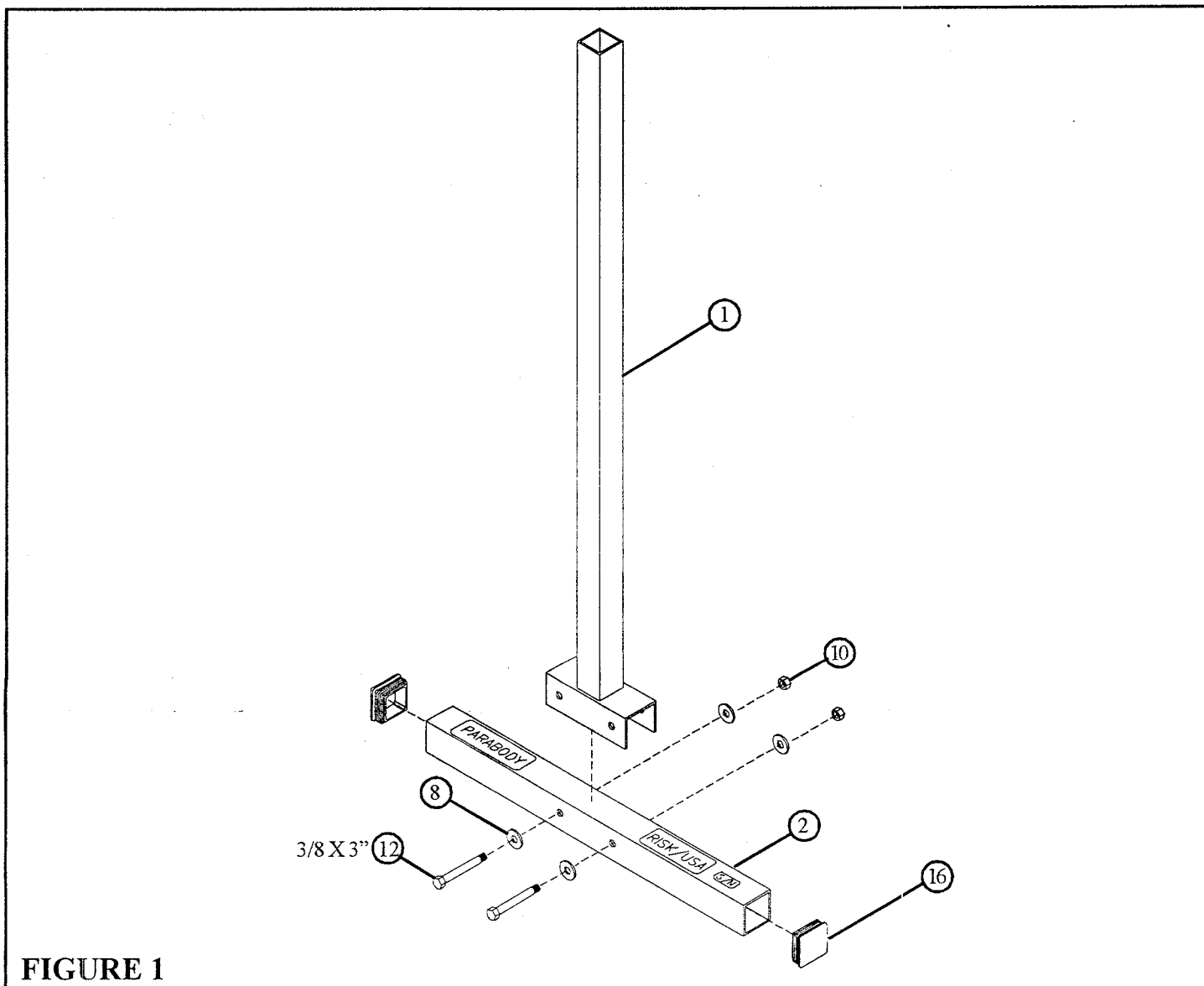

STEP 1:

- Insert two 2" SQ. END CAPS (16) into the ends of the TUBE (2) as shown in FIGURE 1.
- **SECURELY** assemble the TUBE (2) to the FRONT BASE SUPPORT (1) using two 3/8 X 3" BOLTS (12), four 3/8" WASHERS (8), and two 3/8" LOCK NUTS (10). See FIGURE 1.

IMPORTANT NOTES

WELCOME TO THE WORLD OF ***Serious Steel!***

Please note:

- * Thank you for purchasing the Parabody 822104 ADJUSTABLE SIT-UP BENCH. Please read these instructions thoroughly and keep them for future reference. This product must be assembled on a flat, level surface to assure its proper function.
- * We recommend cleaning your product (pads and frame) on a regular basis, using warm soapy water. Touch-up paint can be purchased from your Parabody customer service representative at (800) 328-9714.

There is a risk assumed by individuals who use this type of equipment. To minimize risk, please follow these rules:

1. Inspect equipment daily. Tighten all loose connections and replace worn parts immediately. Failure to do so may result in serious injury.
2. Do not allow minors or children to play on or around this equipment.
3. Exercise with care to avoid injury.
4. If unsure of proper use of equipment, call your local Parabody distributor or call the Parabody customer service department at (800) 328-9714.

Tools Required for Assembly

- * 9/16" wrench
- * Ratchet with 9/16" socket
- * Adjustable wrench
- * Tape measure

Bolt Length Ruler

NOTE: BOLT LENGTH IS MEASURED FROM THE UNDERSIDE OF THE HEAD OF THE BOLT.

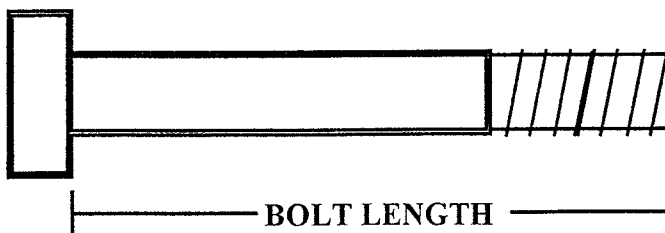

BOLT LENGTH RULER:

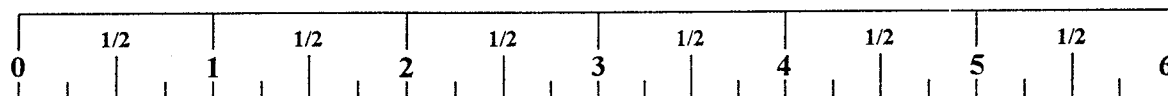

DASH NO	DESCRIPTION
01	AS SHOWN

REVISIONS		
REV	DESCRIPTION	DATE

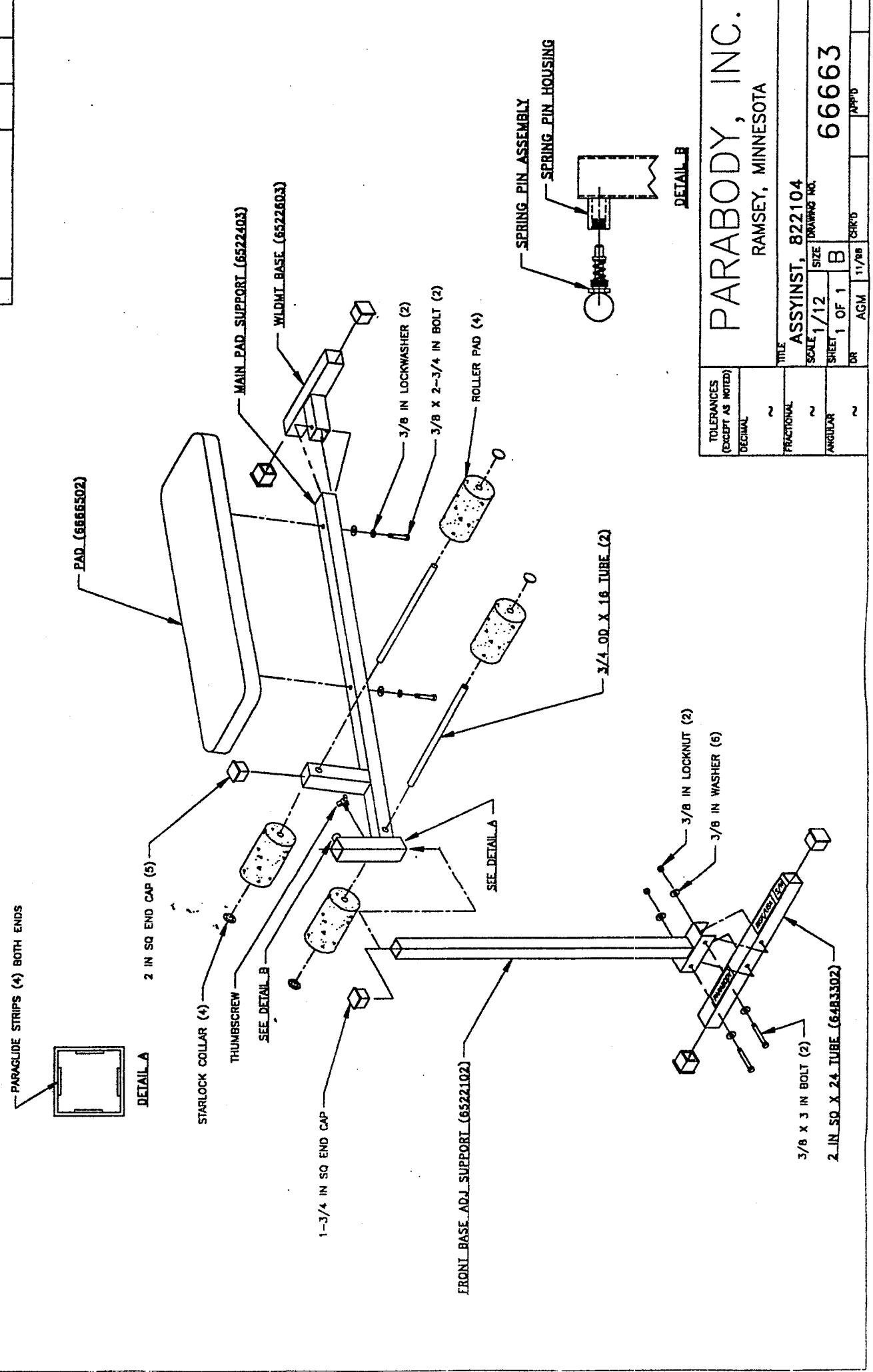

TOLERANCES (EXCEPT AS NOTED)	
DECIMAL	~
FRACTIONAL	~
ANGULAR	~
TITLE	
ASSYINST, 822104	
SCALE	1/12
SHEET	1 OF 1
DR	AGM
CHK'D	11/88
DRAWING NO.	
66663	
PARABODY, INC.	
RAMSEY, MINNESOTA	